

ENGINE MOUNT  
CONSTRUCT FROM  
HARDWOOD AS SHOWN.  
MOUNT IS BOLTED TO  
1/4" PLY. MOTOR MOUNT  
BASE.

1/16" SHEET RIBS -  
23 REQ'D

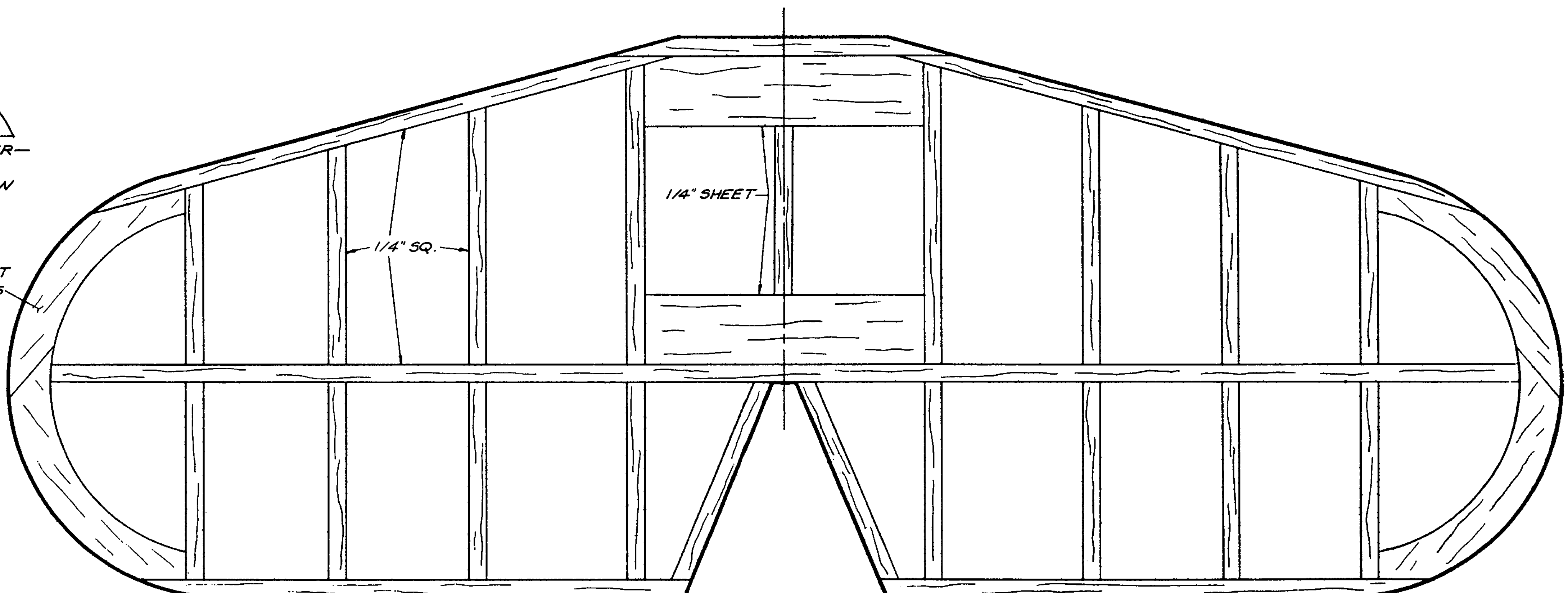

The MODEL BUILDER/magazine  
12322 Del Rey Drive, Santa Ana, California 92705  
**Plan No. 1173-O.T.**  
"MISS TRENTON III"  
BETTER KNOWN AS THE  
**"TRENTON TERROR"**  
DESIGNED BY: MICKEY DeANGELIS  
ORIGINALLY BUILT BY: JAMES ONOFRI  
PUBLISHED IN APRIL 1938 "FLYING ACES"  
DRAWN BY: PHIL BERNHARDT  
SPAN - 72" LENGTH - 41" WEIGHT - 430Z.

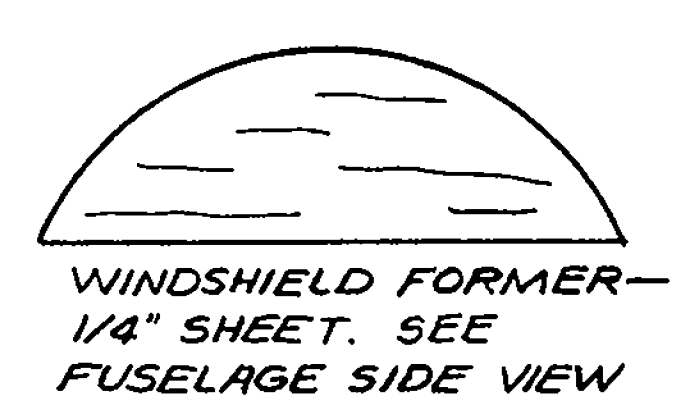
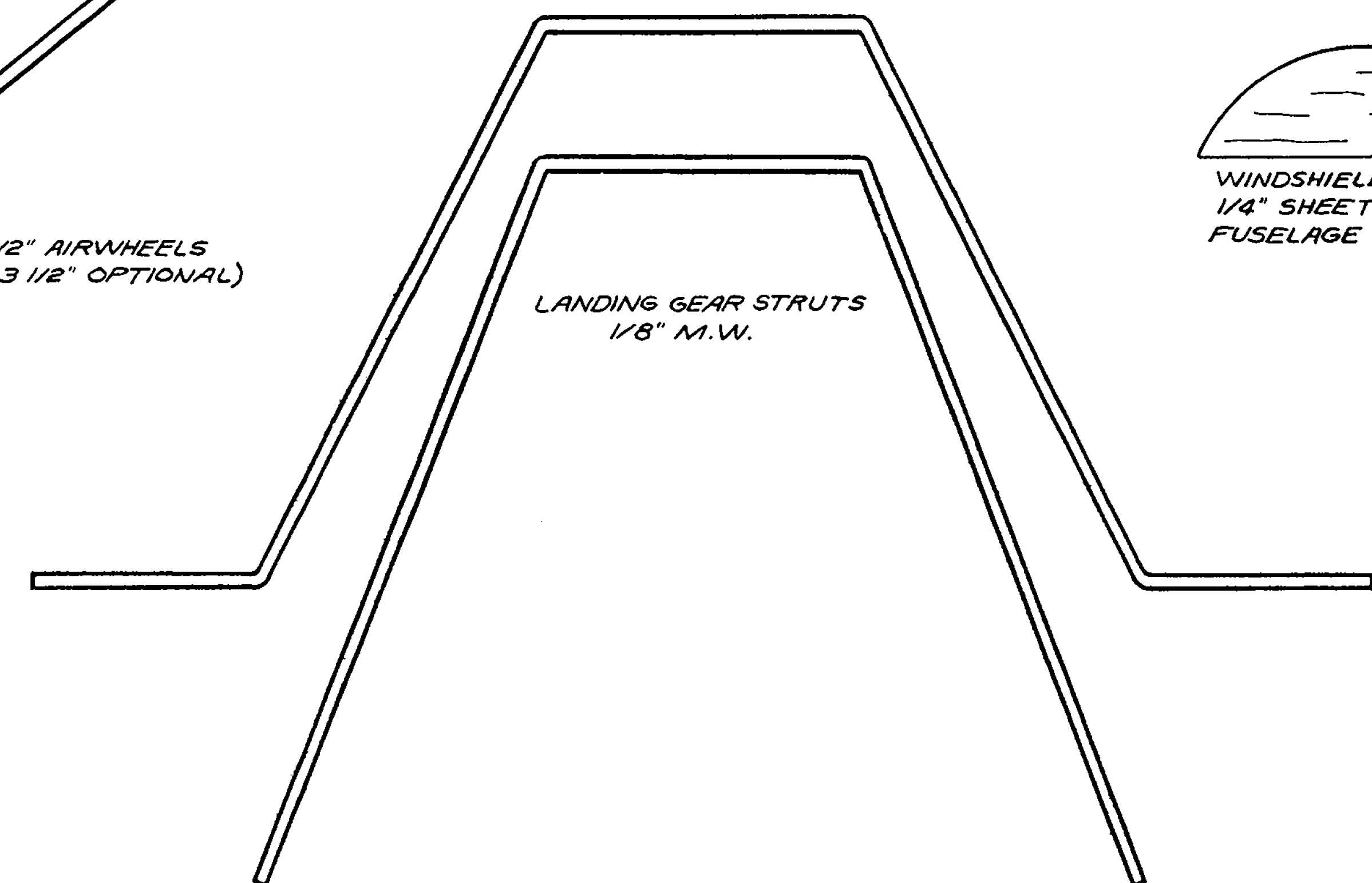
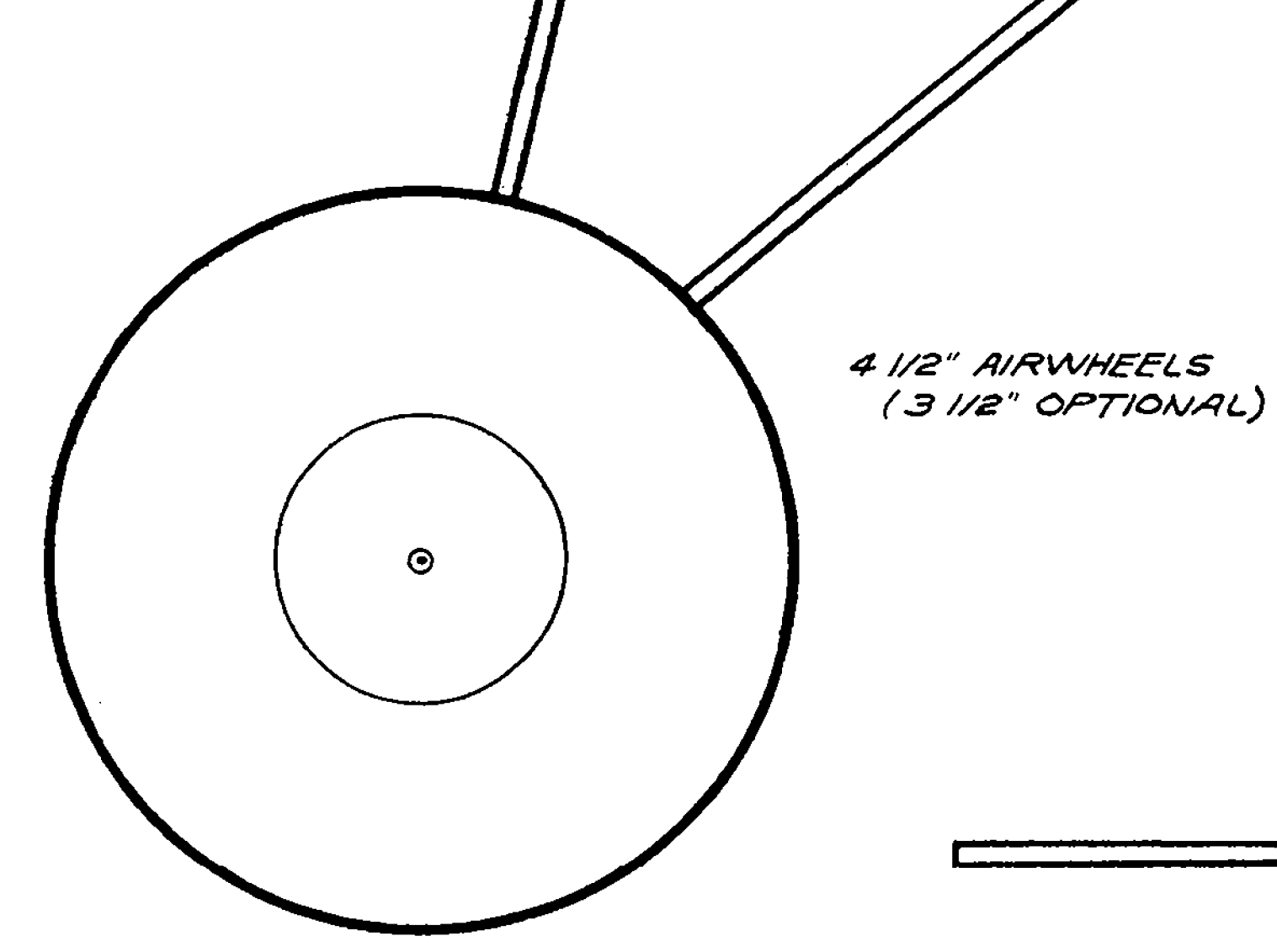
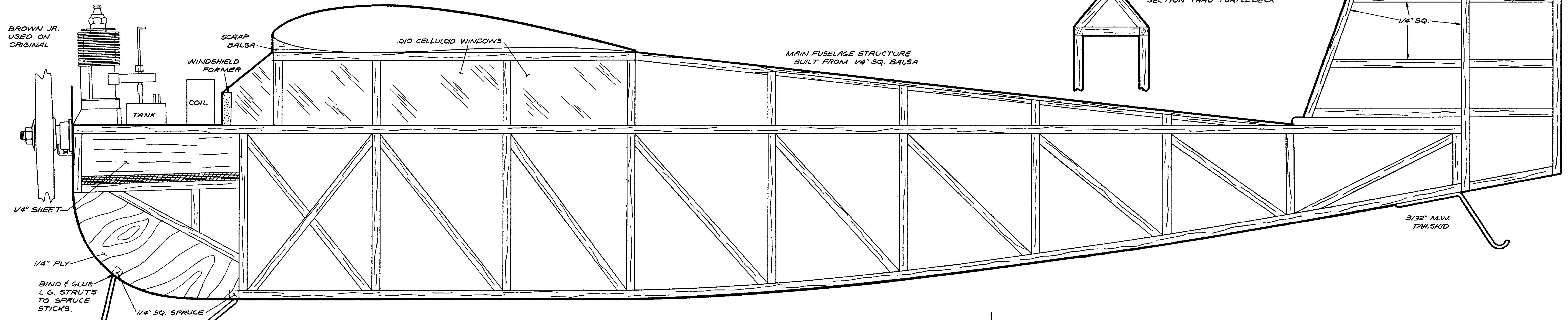
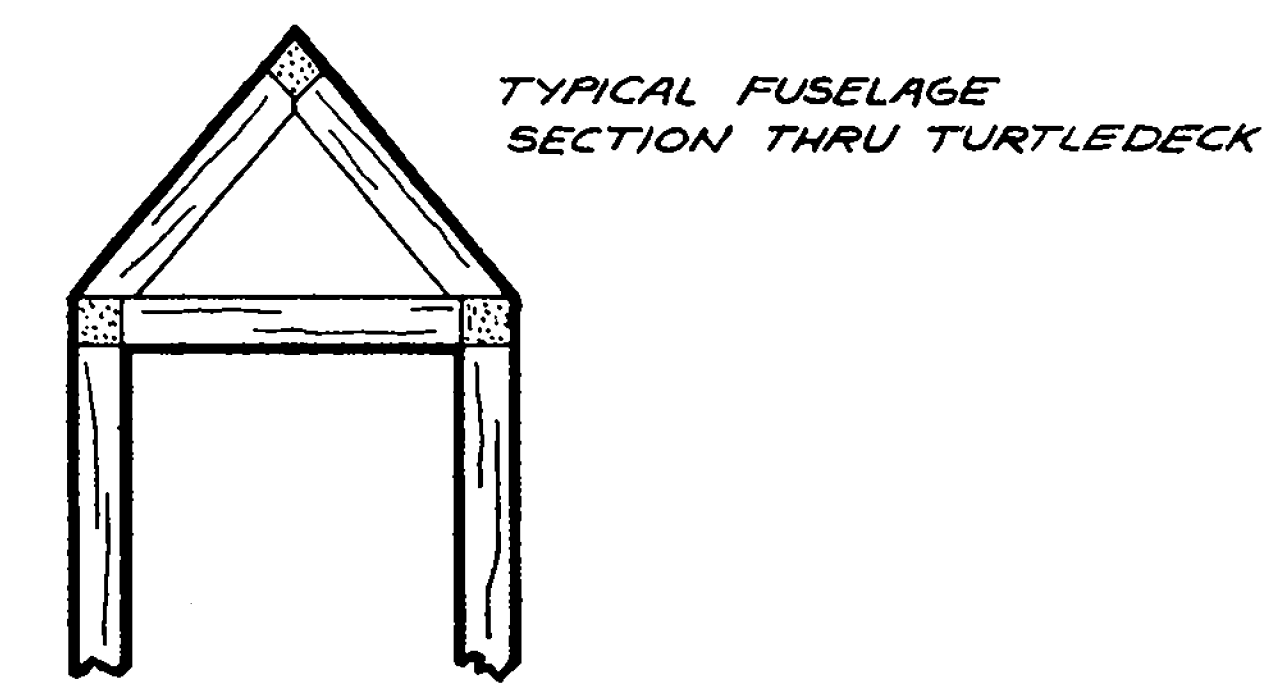
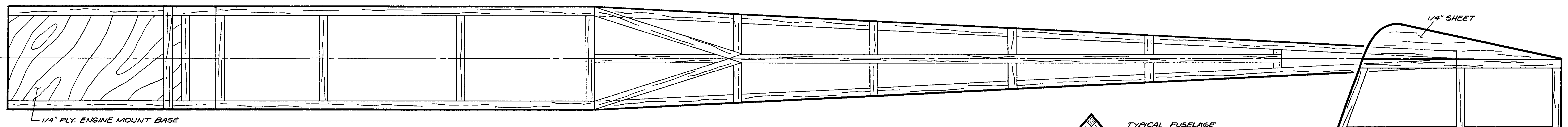

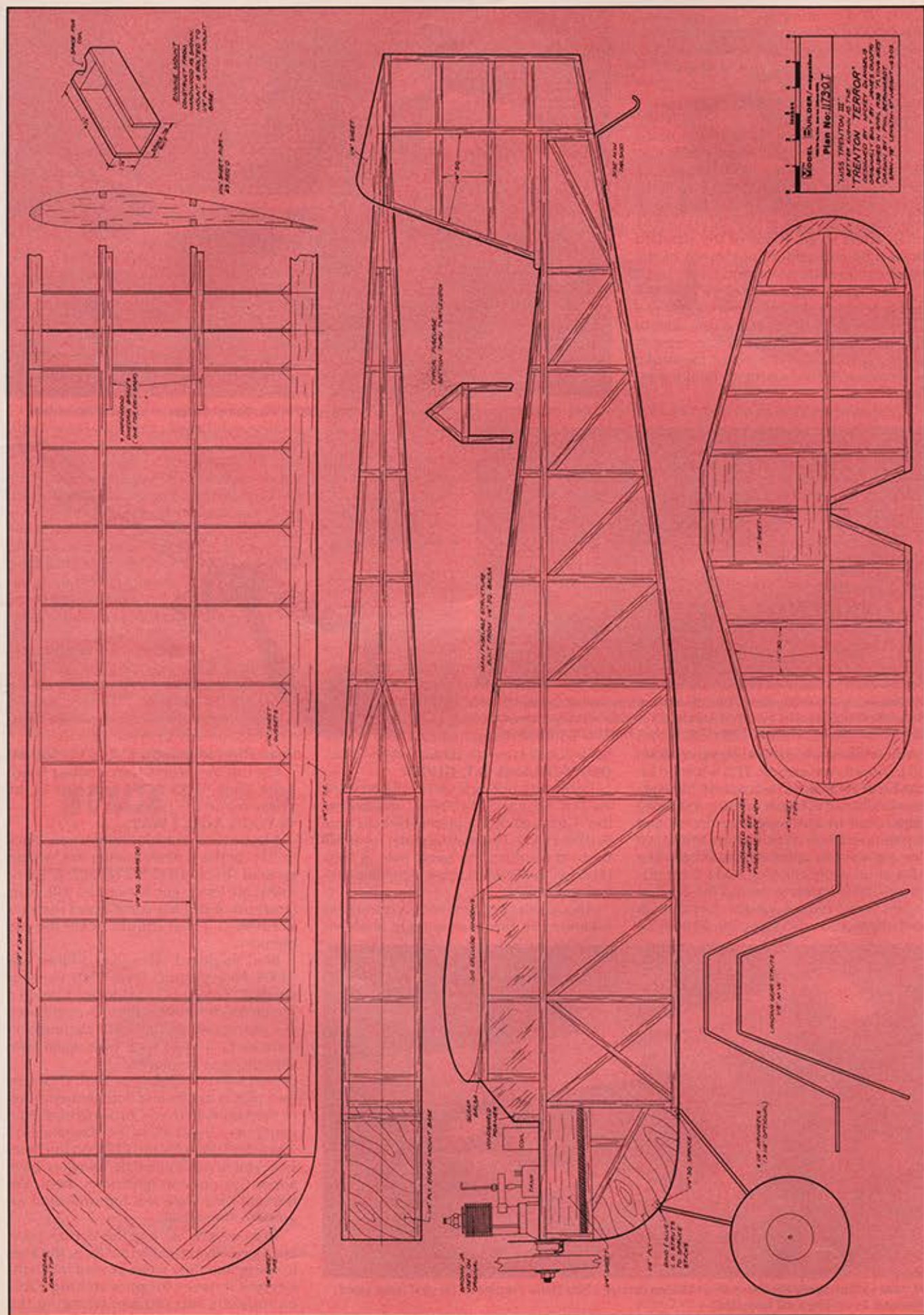

model out in the pattern series of maneuvers.

"I took a picture of his three Madman designs (Photo No. 9) just to remember this incident. Bob and I felt like putting our models back in the car after watching the 'big boys' but decided to give it a try anyway. I have a ninth place medal in Open Stunt from that meet and I am as proud of that award as I am of any other trophy won since.

"Other things that I can remember from the first postwar Nationals was how the California boys arrived in the Ohlsson & Rice DC-3, what style! Seeing Claude McCullough's free flight models; in short, things of beauty. And finally, if I am not senile, the Good brothers had their big R/C 'Guff' there. A great meet for memories."

#### NEW SAM CHAPTER

Nothing like a field to bring the modelers out of the woodwork! Jack Bolton (former SAM Eastern VP) announces the formation of a new SAM Chapter known as CAAMA

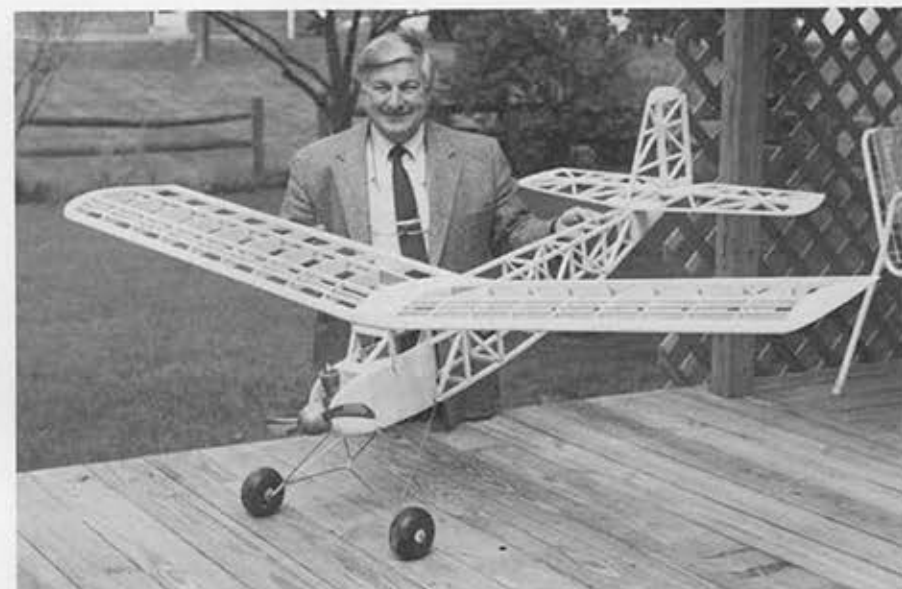

15. John Delagrange did a gorgeous construction job on his "Miss Fortune." This is an earlier version with lower thrust line.



16. Charles Buchanan modified and enlarged his TD Coupe to the point that he has renamed it the CB Coupe.

(Capitol Area Antique Modelers Association), or SAM 10.

Jack is real excited about the free flight field they have been able to obtain; a three-quarter-mile square area with "good fallout" on all sides. Best part of all, the field is located near Culpepper, Virginia, an hour away from the Washington D.C. Beltway.

The club is very diversified in interests: SAM/F, AMA F/F, Nostalgia, Rubber, and of course, SAM R/C Old Timers. This has resulted in a membership of 41.

To start things off right, Jack announces the First CAAMA Fun Contest on June 3 and 4, at the Club field. No lack of events as there are four SAM F/F events, five SAM R/C events, two AMA Gas, two NFFS Nostalgia, two special SAM events (Ohlsson .23 and .020 Replica), plus three rubber events. Whew!

To keep things on strictly a fun basis, there will be no entry fees, instead a one-time \$2.00 registration fee will be charged.

Continued on page 81

## Trenton Terror



• Featuring an Old Timer plan in each issue of *Model Builder* is a tradition that was begun early in the magazine's history, and the "Trenton Terror" was one of the first. That was back in November of 1973, or 185 issues ago. Many of you readers have joined us since then, so we're reprinting the plan this month for those who missed it the first time around.

The Trenton Terror originally appeared in the April 1938 issue of *Flying Aces*. Actually that's not the model's real name; Mickey DeAngelis, who designed the ship, was a member of the Trenton Gas Model Airplane Club and was himself known as the "Trenton Terror" by his clubmates. When he designed this particular model it was Billy Giblin, who drew the four-page plan for *Flying Aces* and who has the distinction of having played one of the Munchkins in *The Wizard of Oz*, who suggested calling it by its designer's nickname.

Continued on page 84